

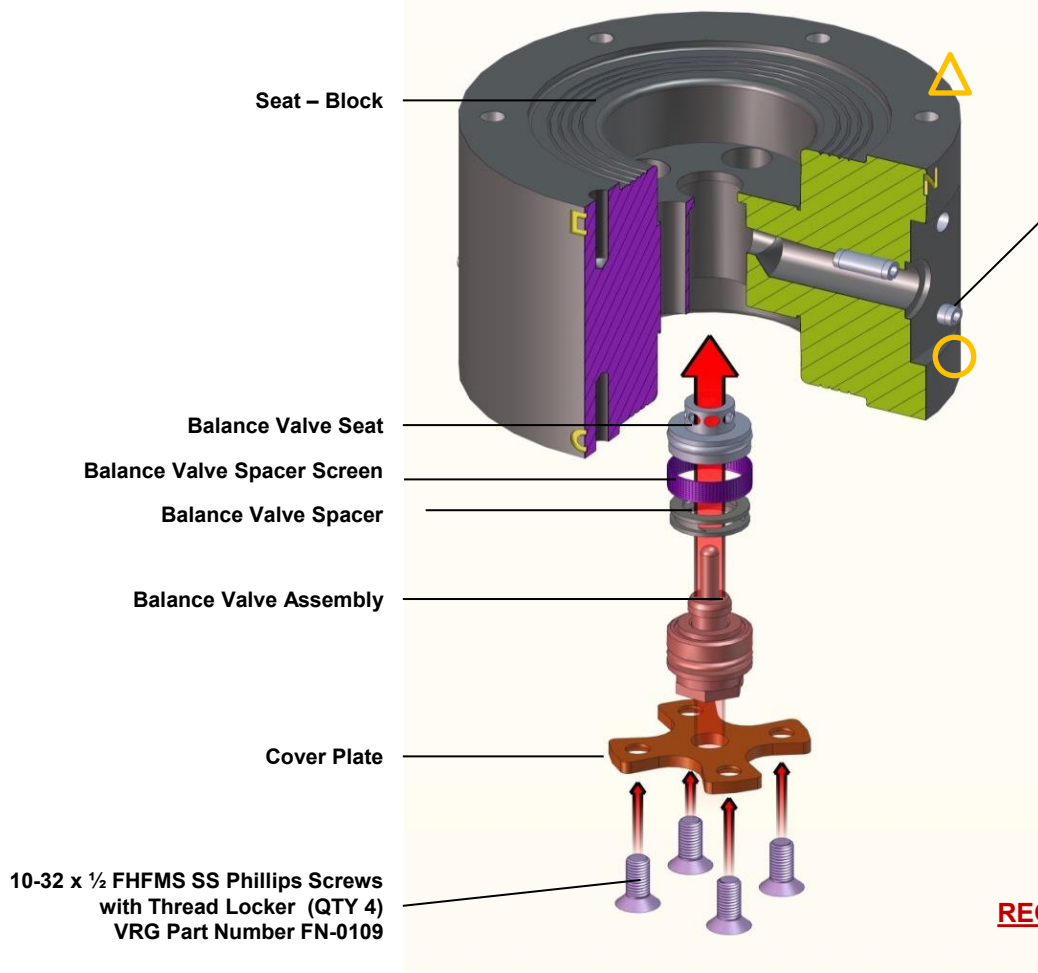

VRG
CONTROLS

**VPC-SA-BV
Pilot Blank
Assembly
Instructions**

Install Nozzle Block into Seat Block Assembly



Instructions:

1. Insert 3/16 x 1/2 Roll Pins into Seat Block
2. Apply light silicon grease to all O-Rings, threads, thrust bearing and spring seat.
3. Press Balanced Valve Seat assembly into Pilot Block as shown.
4. Insert Balanced Valve Spacer & Spacer Screen into Pilot Block as shown.
5. Insert Balanced Valve into Pilot Block as shown
6. Insert 10-32 x 1/2 FHFMS SS Phillips Screws with Thread Locker into bottom of Body and tighten.

RECOMMENDED LUBRICANT: Mobilith SHC 220

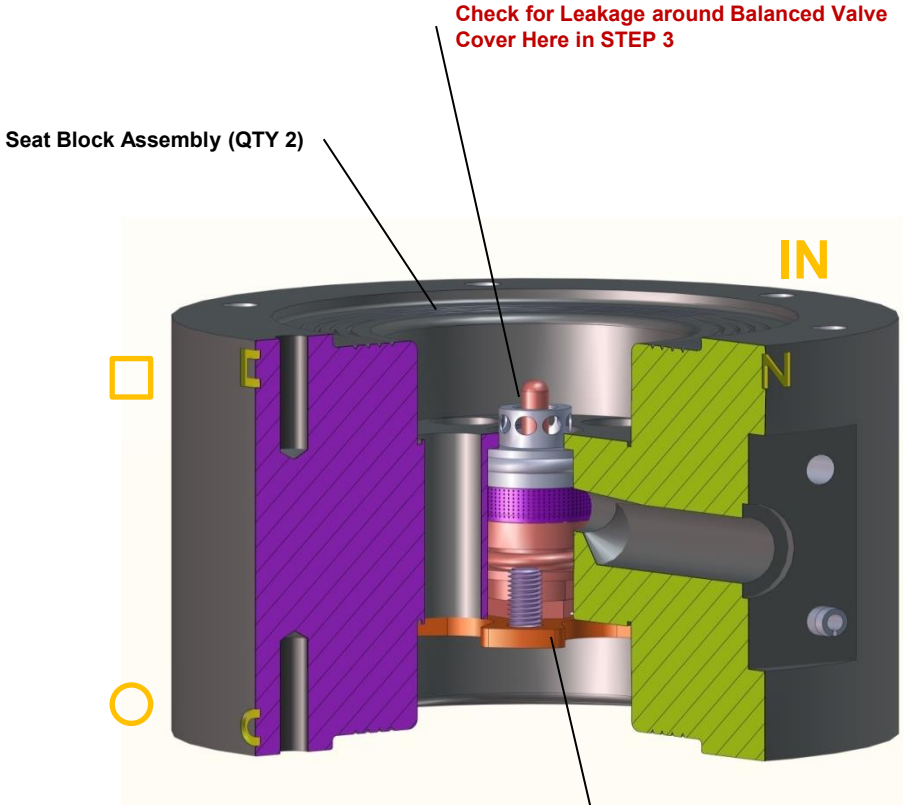

Instructions:

1. Before assembling balance of VPC, it is critical to confirm integrity of Balanced Valve Seats via a pressure test.
2. Install NPT Block Test Manifold on "IN" side of Pilot Block Assembly using 1/4-20 x 5/8 SHCS (QTY 2). Be sure to install .014 O-Ring during process as shown.
3. Apply 100 psig air to the port marked "IN" and soap test for leakage around Balanced Valve Seat where Balanced Valve protrudes from Pilot Block and around Balanced Valve Cover on opposite end.
4. If leak is found, check for contamination or debris at Balanced Valve Seat and O-Rings on Balanced Valve Assembly.
5. If leak if found repeat Step 1.

Install Pistons into Top Seat Block Assembly

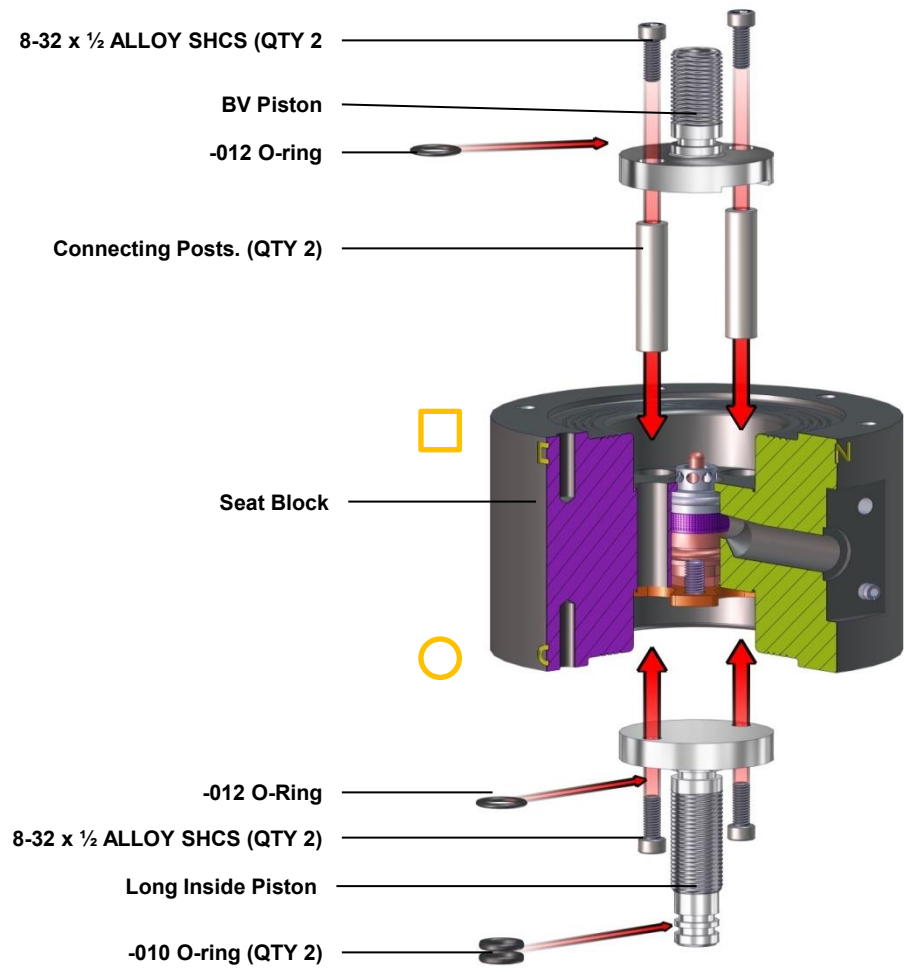

Instructions:

1. Lubricate -012 O-ring and install on BV Piston
2. Lubricate -010 O-rings and install on Long Inside Piston
3. Lubricate -012 O-ring and install on Long Inside Piston
4. Install 8-32 x 1/2 ALLOY SHCS through BV Piston and install Connecting Posts. Insert assembly into Body.
5. Install 8-32 x 1/2 ALLOY SHCS through Long Inside Piston and tighten to Connecting Posts already inserted through block assembly.

Top Seat Block Assembly with Pistons Installed

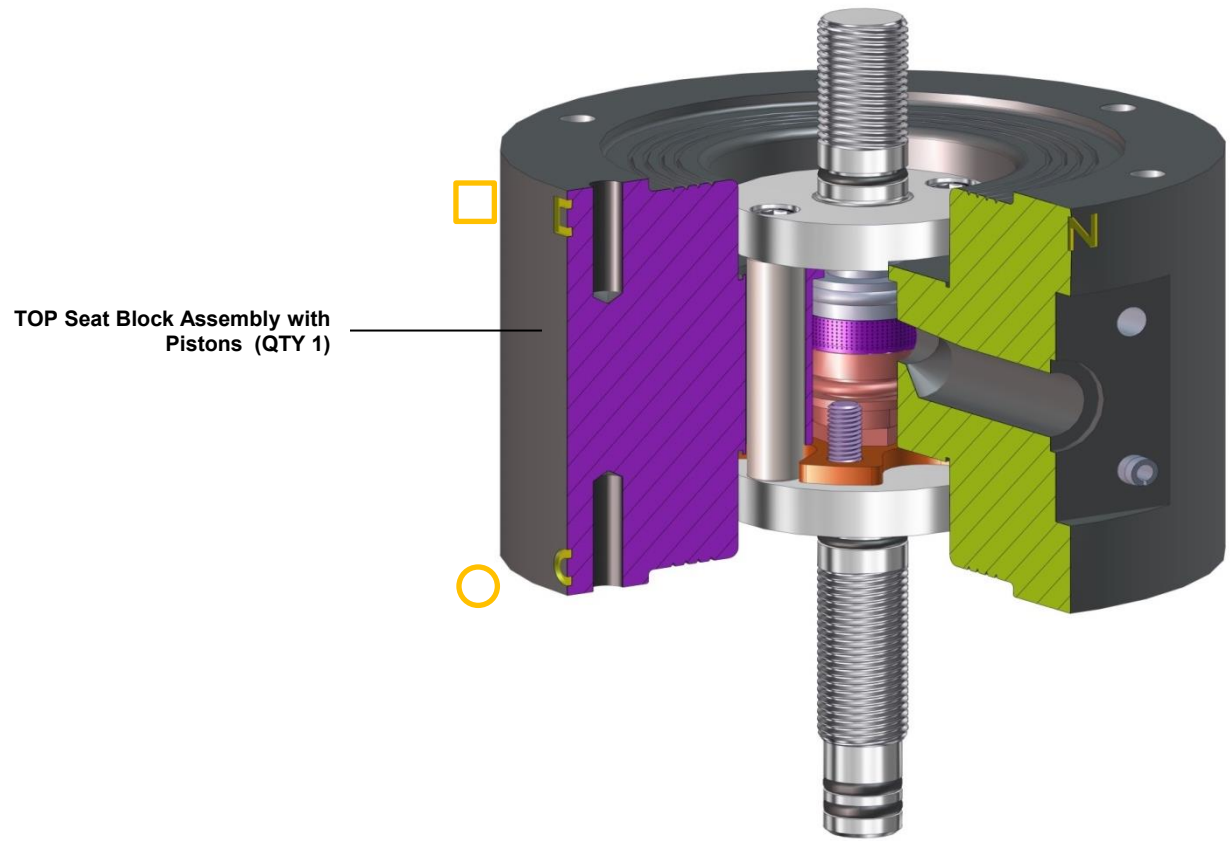

Install -700 Diaphragms on Top Seat Block Assembly

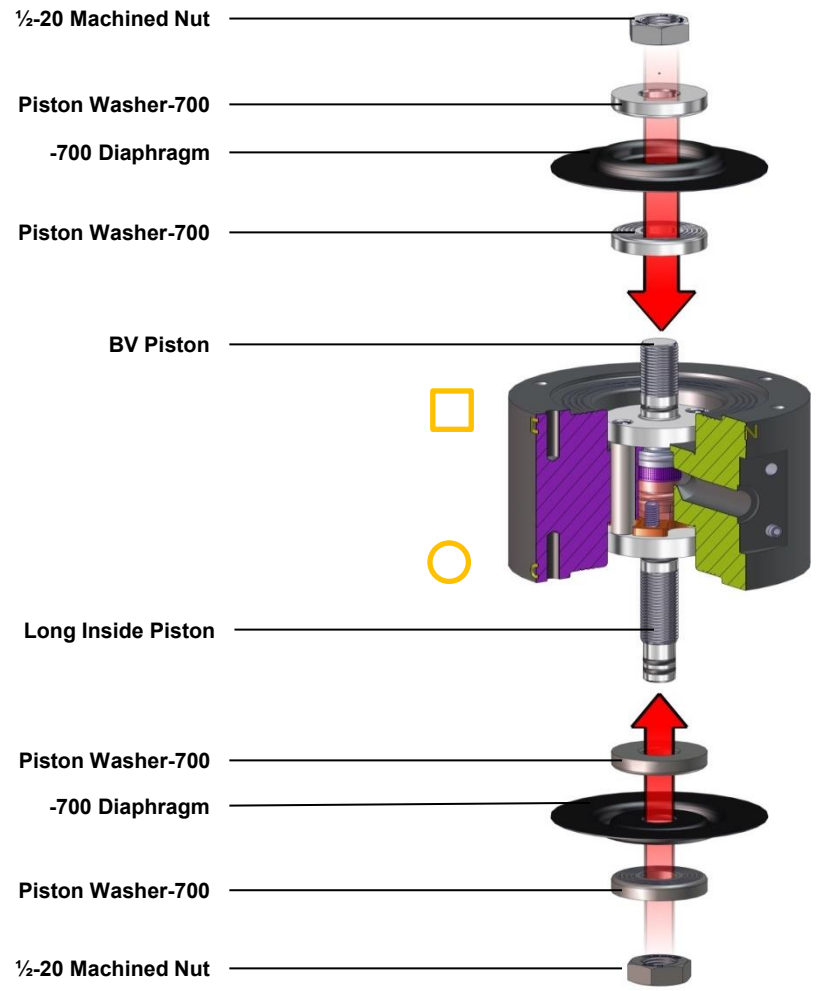

Instructions:

1. Apply Piston Washer-700 on BV Piston with serrations facing UP
2. Install -700 Diaphragm onto BV Piston with convolute facing UP
3. Install Piston Washer-700 on BV Piston with serrations facing DOWN
4. Install 1/2-20 Machined Nut onto BV Piston and torque to 110 in-lbs.
5. Apply Piston Washer-700 on Long Inside Piston with serrations facing DOWN
6. Install -700 Diaphragm onto Long Inside Piston with convolute facing DOWN
7. Apply Piston Washer-700 on Long Inside Piston with serrations facing UP
8. Install 1/2-20 Machined Nut onto Long Inside Piston and torque to 110 in-lbs.

Top Seat Block Assembly with Diaphragms Installed



Top Seat Block Assembly with Diaphragms Installed (QTY 1)

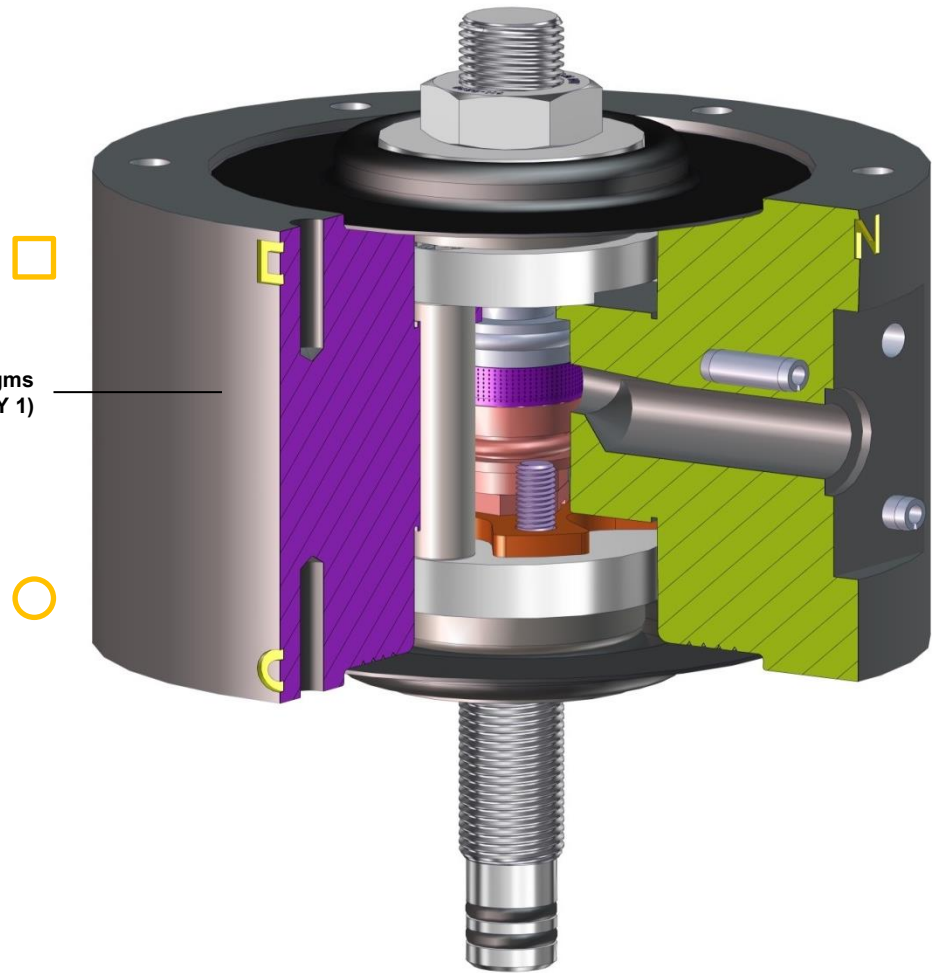

Install Pistons into Bottom Seat Block Assembly

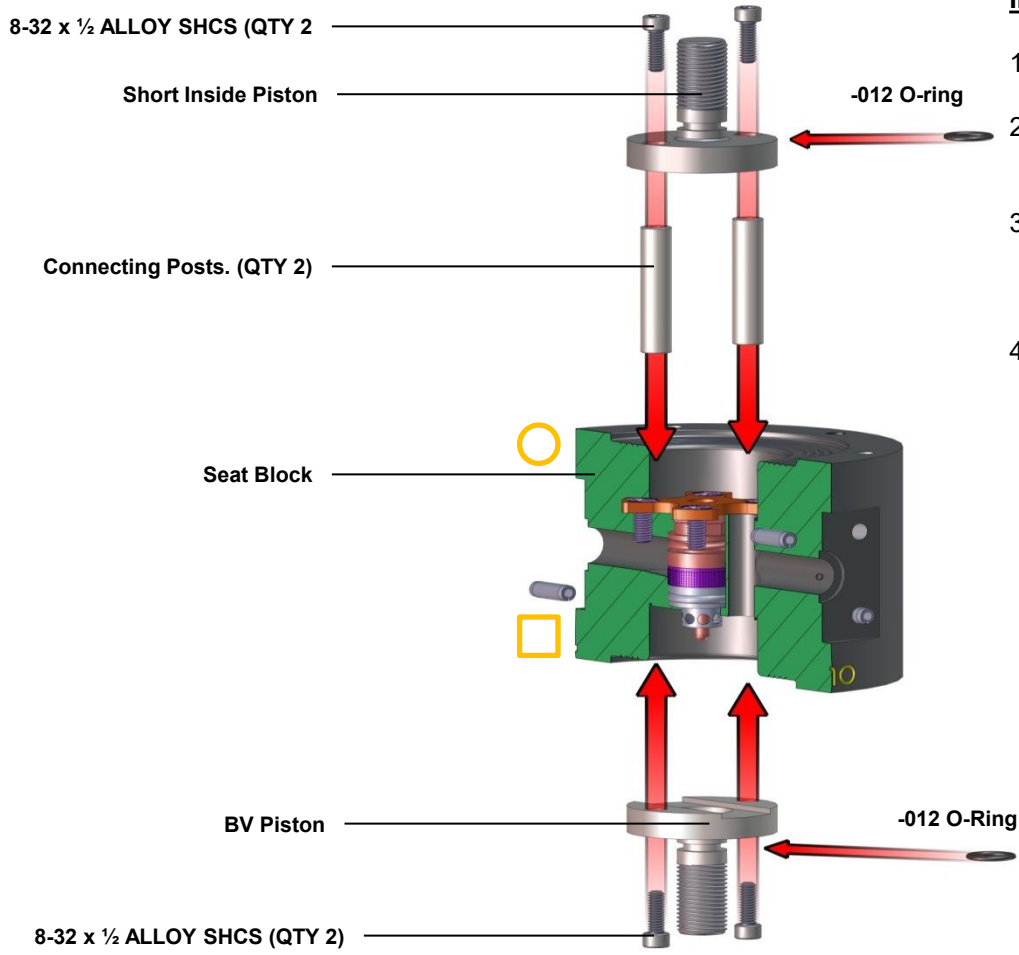

Instructions:

1. Lubricate -012 O-ring and install on BV Piston
2. Lubricate -012 O-ring and install on Short Inside Piston
3. Install 8-32 x 1/2 ALLOY SHCS through BV Piston and install Connecting Posts. Insert assembly into Body.
4. Install 8-32 x 1/2 ALLOY SHCS through Short Inside Piston and tighten to Connecting Posts already inserted through block assembly.

Bottom Seat Block Assembly with Pistons Installed



Bottom Seat Block Assembly with
Pistons Installed (QTY 1)

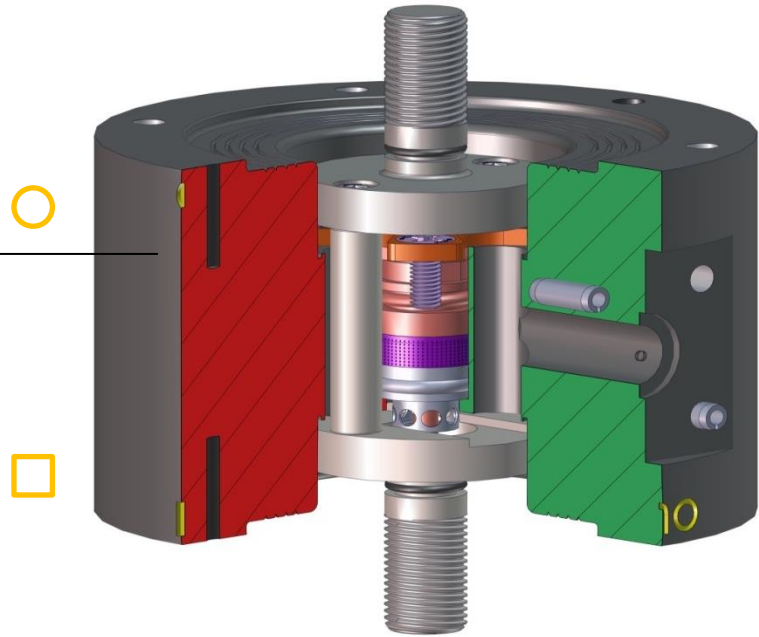

Install -700 Diaphragms into Bottom Seat Block Assembly

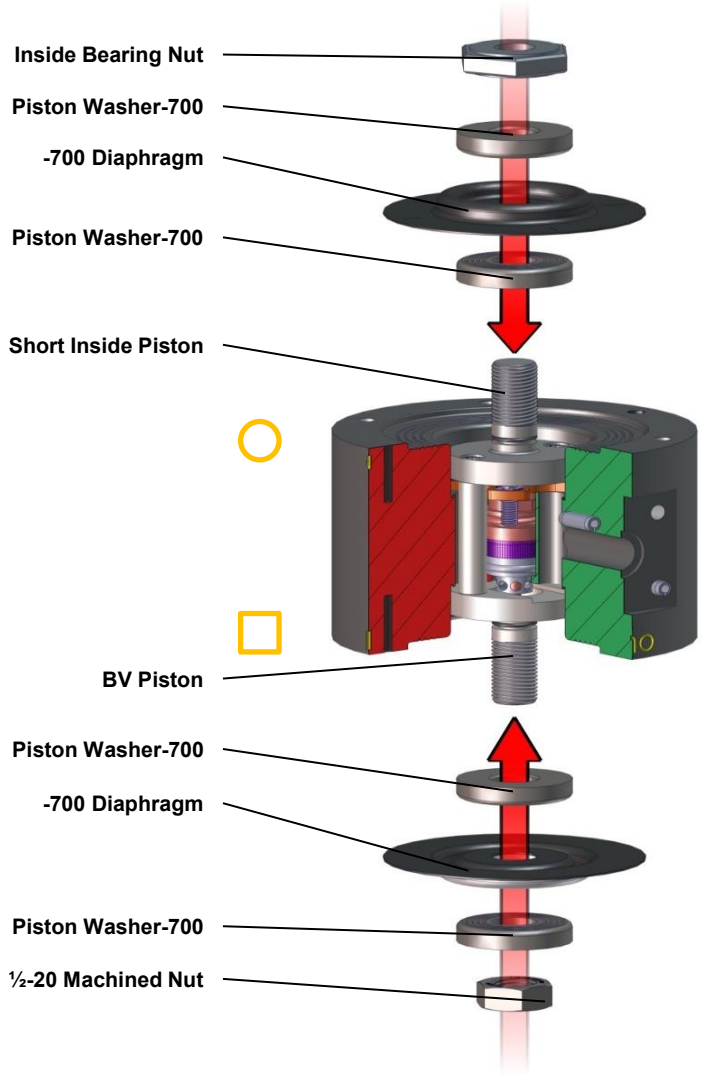

Instructions:

1. Apply Piston Washer-700 on BV Piston with serrations facing DOWN
2. Install -700 Diaphragm onto BV Piston with convolute facing DOWN
3. Install Piston Washer-700 on BV Piston with serrations facing UP
4. Install 1/2-20 Machined Nut onto BV Piston and torque to 110 in-lbs.
5. Apply Piston Washer-700 on Short Inside Piston with serrations facing UP
6. Install -700 Diaphragm onto Short Inside Piston with convolute facing UP
7. Apply Piston Washer-700 on Short Inside Piston with serrations facing DOWN
8. Install Inside Bearing Nut onto Short Inside Piston and torque to 110 in-lbs.

Bottom Seat Block Assembly with Diaphragms Installed



Bottom Seat Block Assembly with Diaphragms Installed (QTY 1)

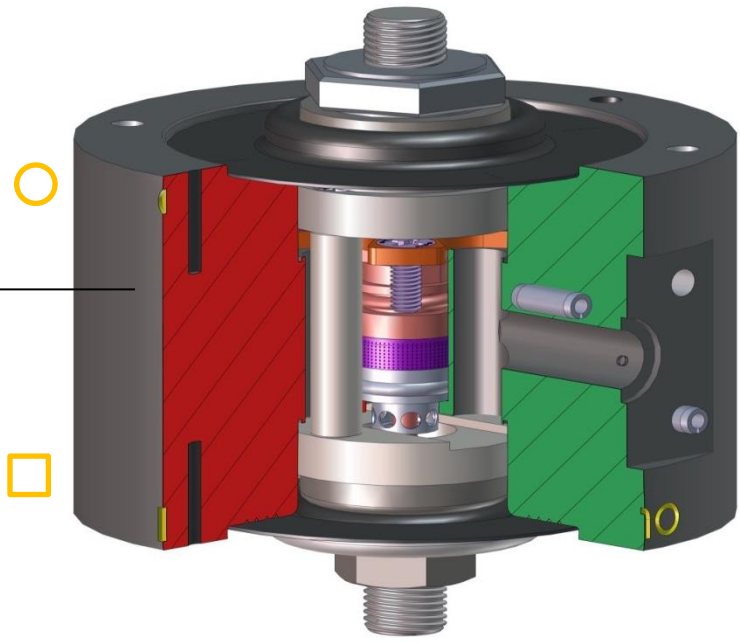

Install Thrust Bearing into Adjusting Drum

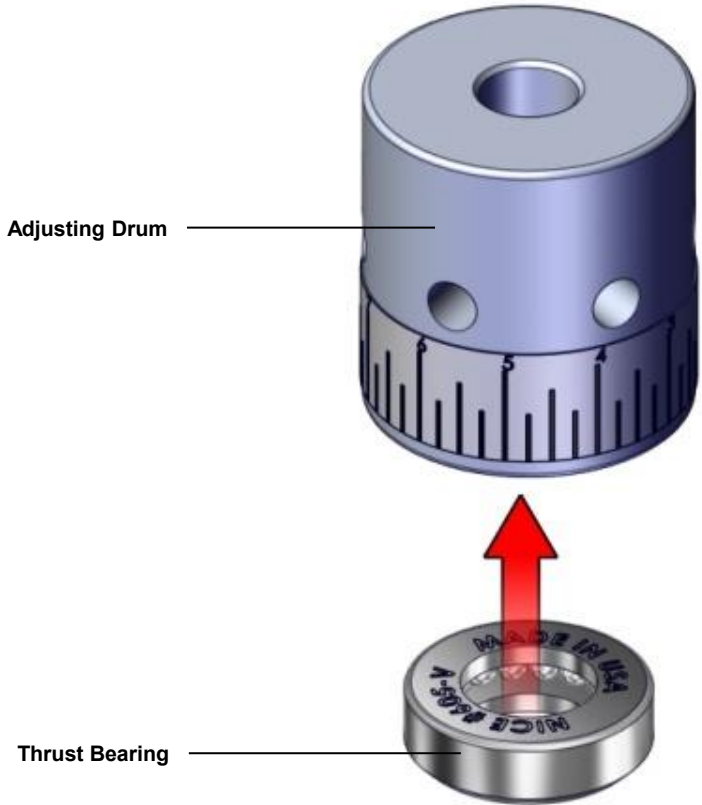

Instructions:

1. Press Thrust Bearing into Sensitivity Drum with stamped letters side first. Bearing case should fit snugly inside Adjusting Drum and bearing surface should face outward and rotate freely.
2. ATTENTION: The Thrust Bearing should fit completely down to inner surface of Adjusting Drum and should be level around perimeter to avoid slant or side load.
3. Lubricate inside threads of Adjusting Drum liberally



Adjusting Drum with Thrust Bearing Installed



Install Adjusting Drum Onto Top Seat Block Assembly

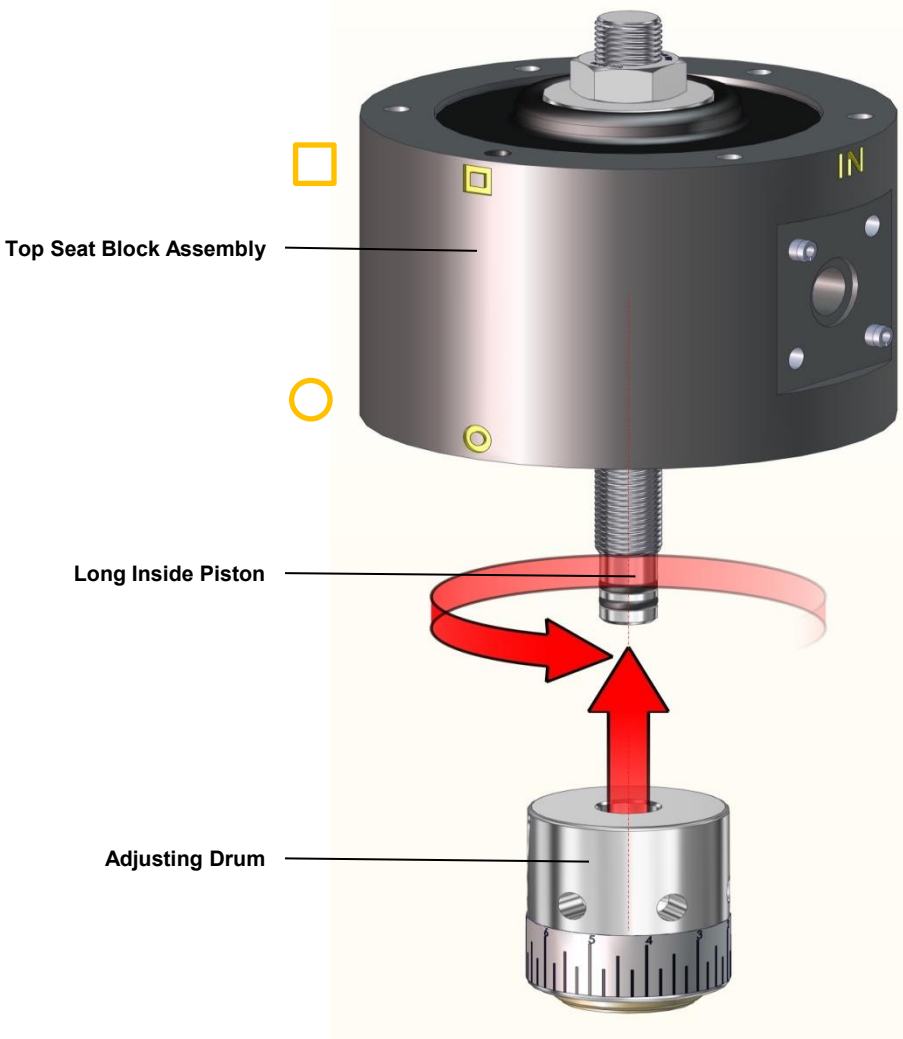

Instructions:

1. Apply lubrication to Long Inside Piston
2. Install Adjusting Drum onto Top Seat Block Assembly by threading onto Long Inside Piston until it just bottoms out against 1/2-20 JAM Nut.
3. Rotate the Adjusting Drum so 1.5 turns of disengagement from Long Inside Piston

Top Seat Block Assembly with Adjusting Drum Installed



Top Seat Block Assembly with Adjusting Drum Installed (QTY 1)



Install Pilot Spacer onto Top Pilot Block Assembly

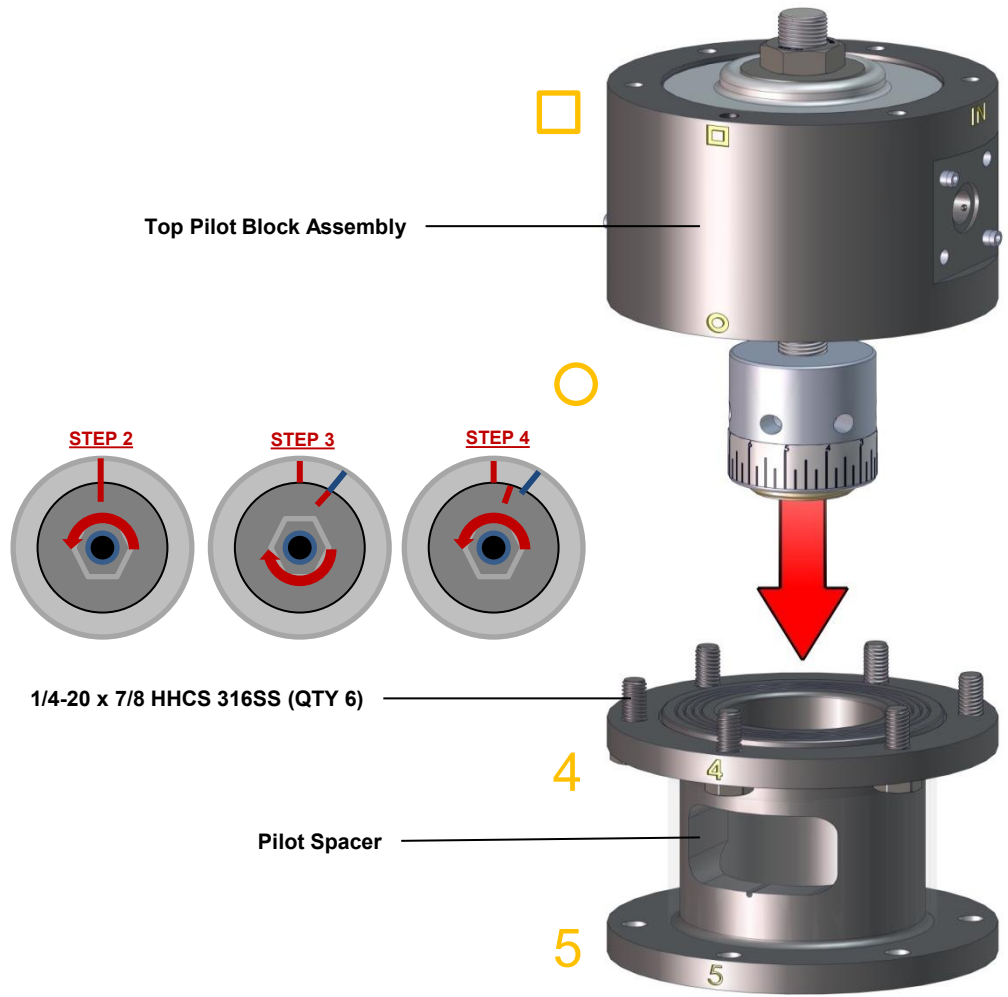

Instructions:

1. **ATTENTION:** Center Connecting Posts assemblies within Top Pilot Block Assembly as follows to avoid friction (rubbing):
2. Rotate diaphragm assemblies counterclockwise (CCW) until it stops & place a single pencil mark across the diaphragm and top surface of the Top Pilot Block Assembly.
3. Now Rotate diaphragm assemblies clockwise (CW) until it stops & place a single pencil mark extended from the first diaphragm mark across the top surface of the Top Pilot Block Assembly.
4. Now Rotate diaphragm assemblies counterclockwise (CCW) slightly until the single pencil mark on the diaphragm is approximately half way between the two (2) pencil marks on the top surface of the Top Pilot Block Assembly.
5. Keeping the diaphragms securely in centered positions, fasten the Top Pilot Block Assembly to the Pilot Spacer using 1/4-20 x 7/8 HHCS 316SS.
6. This will secure each diaphragm assembly and maintain it in "centered" position.
7. **ATTENTION:** Be certain to **ALIGN** VPC Identification Symbols appropriately as shown to ensure proper configuration.

Install Bottom Pilot Block Assembly

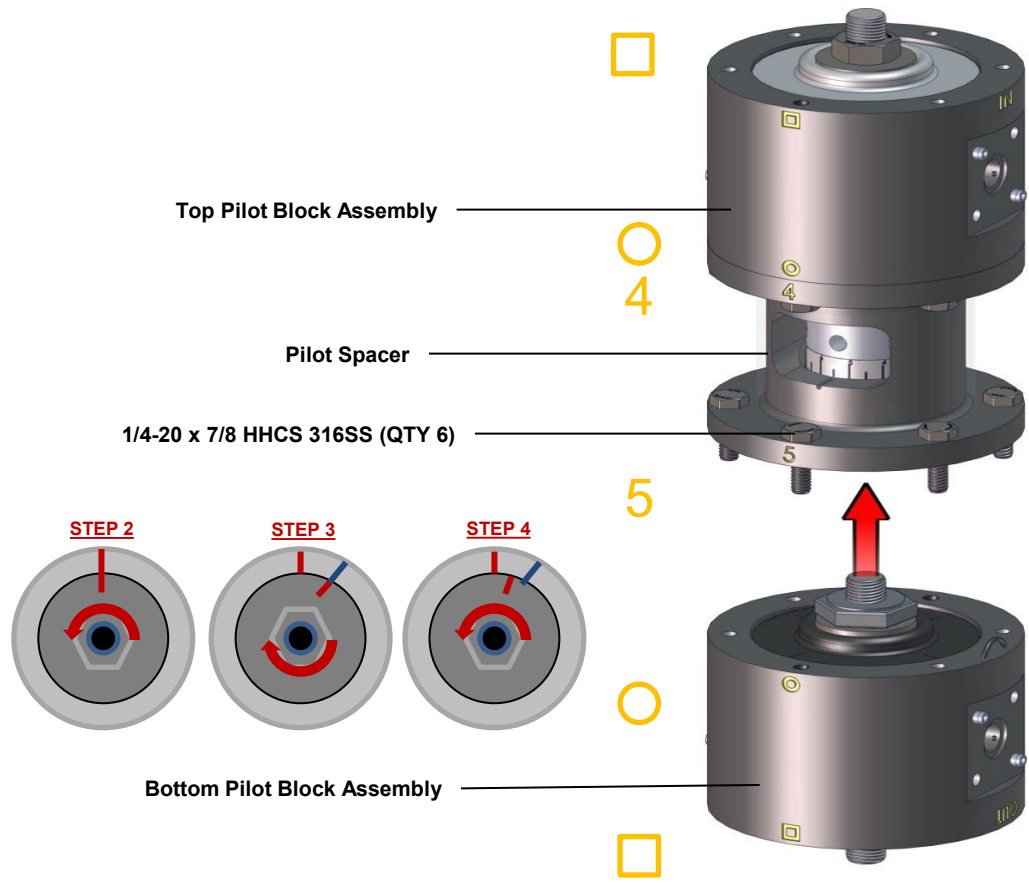

Instructions:

1. **ATTENTION:** Center Connecting Posts assemblies within Bottom Pilot Block Assemblies as follows to avoid friction (rubbing):
2. Rotate diaphragm assemblies counterclockwise (CCW) until it stops & place a single pencil mark across the diaphragm and top surface of the Bottom Pilot Block Assembly.
3. Now Rotate diaphragm assemblies clockwise (CW) until it stops & place a single pencil mark extended from the first diaphragm mark across the top surface of the Bottom Pilot Block Assembly.
4. Now Rotate diaphragm assemblies counterclockwise (CCW) slightly until the single pencil mark on the diaphragm is approximately half way between the two (2) pencil marks on the top surface of the Top Pilot Block Assembly.
5. Keeping the diaphragms securely in centered positions, fasten the Bottom Pilot Block Assembly to the Pilot Spacer using 1/4-20 x 7/8 HHCS 316SS.
6. This will secure each diaphragm assembly and maintain it in "centered" position.
7. **ATTENTION:** Be certain to ALIGN VPC Identification Symbols appropriately as shown to ensure proper configuration.

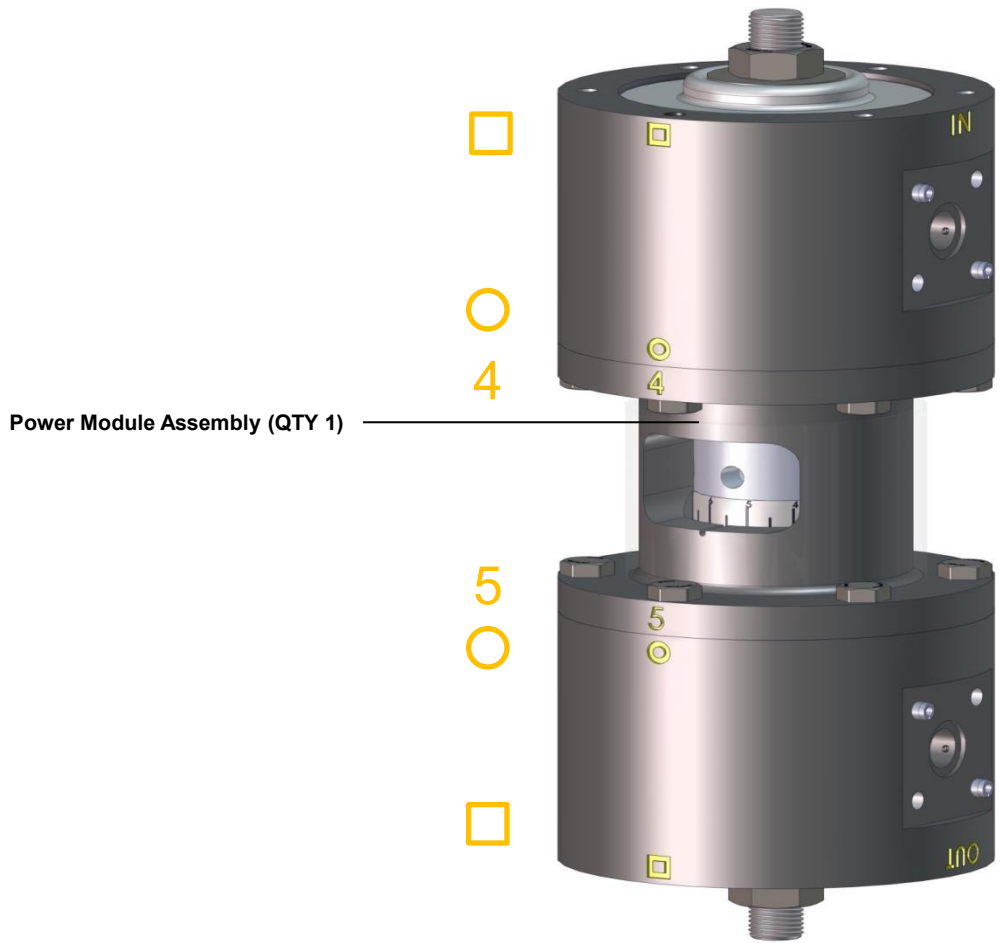

Power Module Assembly (QTY 1)

Install Pilot Bottom Flange onto Power Module Assembly

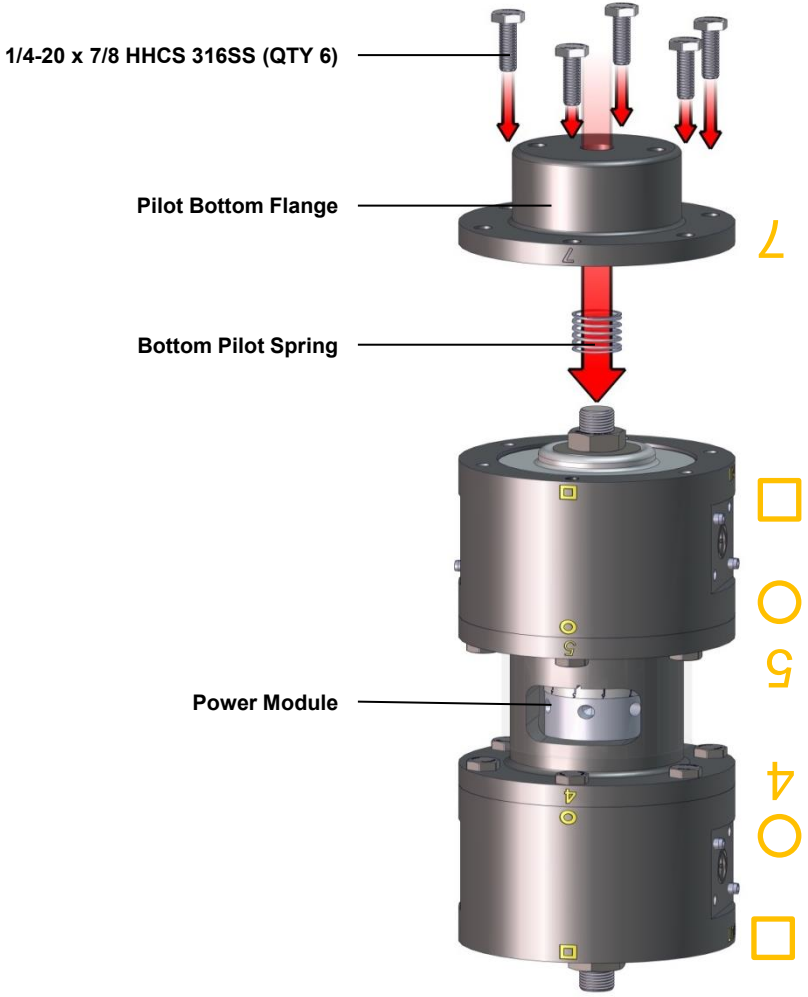

Instructions:

1. Flip the Power Module Assembly upside down and install Bottom Pilot Spring as shown onto threaded end of piston.
2. Lubricate Bottom Pilot Spring
3. Install Pilot Bottom Flange onto Power Module Assembly ensuring that Bottom Return Spring fits inside internal cavity of Pilot Bottom Flange.
4. Secure Pilot Bottom Flange with 1/4-20 x 7/8 HHCS 316SS.
5. ATTENTION: Be certain to ALIGN VPC Identification Symbols appropriately as shown to ensure proper configuration.

Power Module Assembly with Pilot Bottom Flange Installed



Power Module Assembly with Pilot Bottom Flange Installed (QTY 1)



- 7
-
-
- 5
-
- 4
-
-



Install Connecting Manifolds to Power Module Assembly

Instructions:

1. Apply thin film of lubricant to .014 O-Rings to facilitate assembly.
2. Adhere .014 O-Rings to cavities on either side of Power Module Assembly (QTY 4).
3. Install Connecting Manifolds (QTY 2) to Power Module Assembly using 1/4-20 5/8 SHCS (QTY 8).

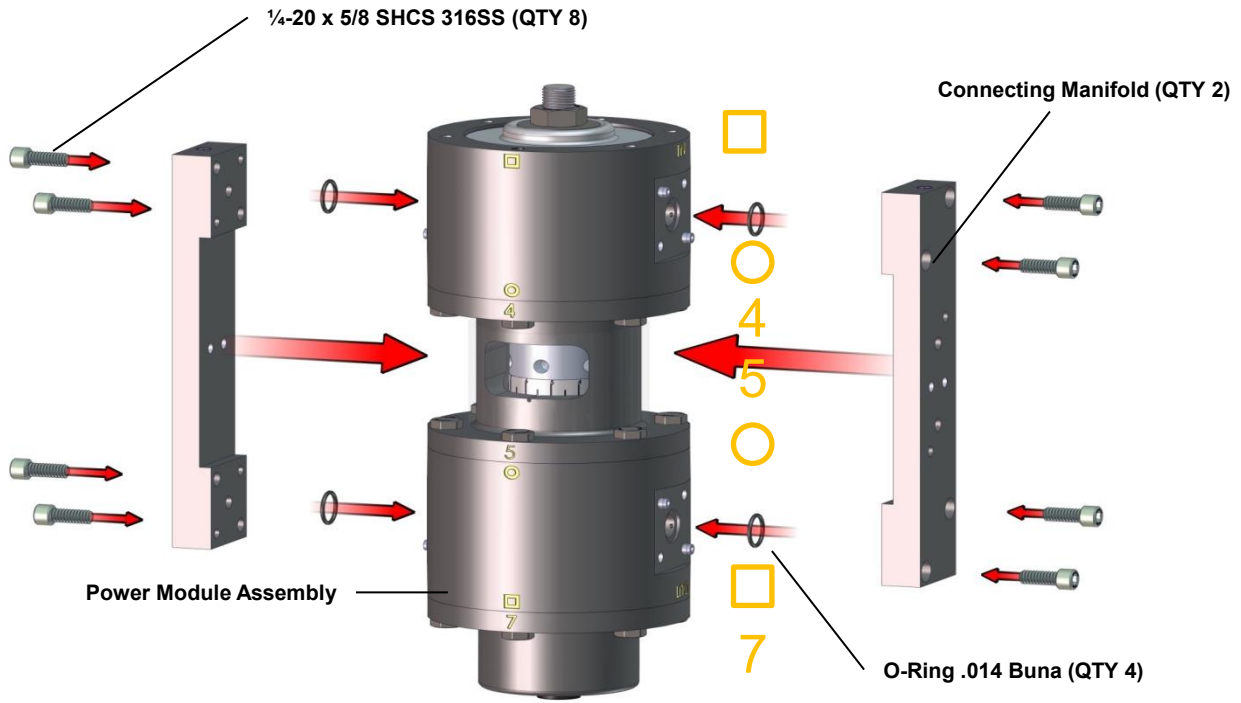

Pilot Blank Assembly with Connecting Manifolds Installed



Pilot Blank Assembly with Connecting Manifolds Installed

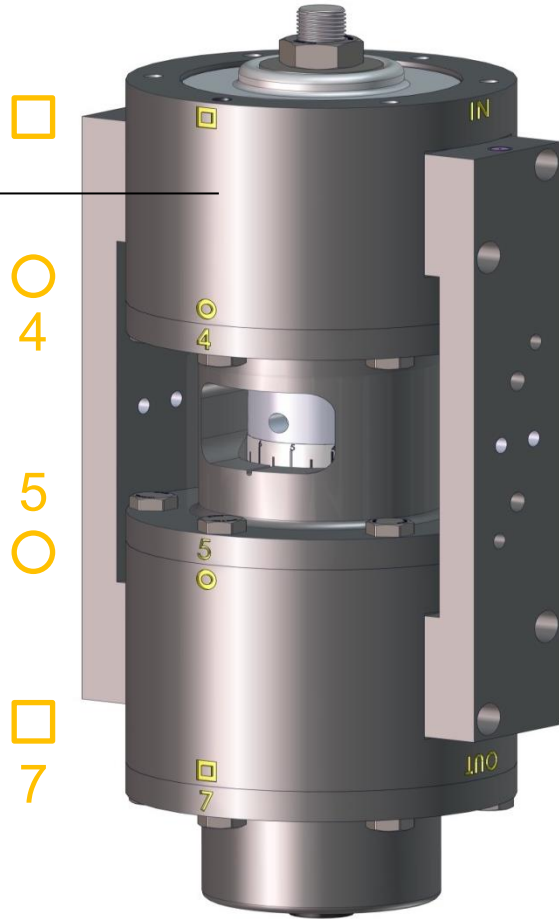

Attach Pilot Blank Assembly to Mounting Bracket

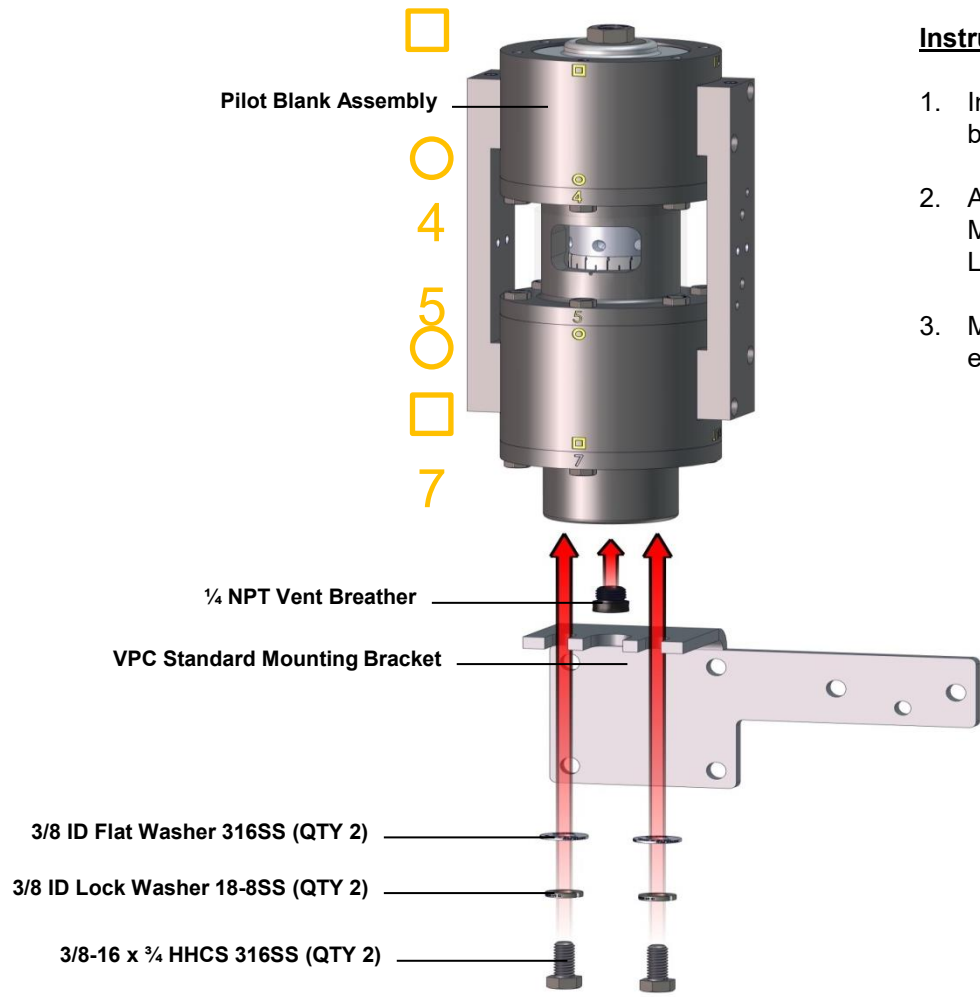

Instructions:

1. Install 1/4 NPT Vent Breather into NPT port on bottom of Pilot Blank Assembly.
2. Attach Pilot Blank Assembly to VPC Standard Mounting Bracket as shown using Flat Washers, Lock Washers and 3/8-16 x 3/4 HHCS.
3. Maintain Pilot Blank Assembly vertical position to ensure proper alignment of internal components