

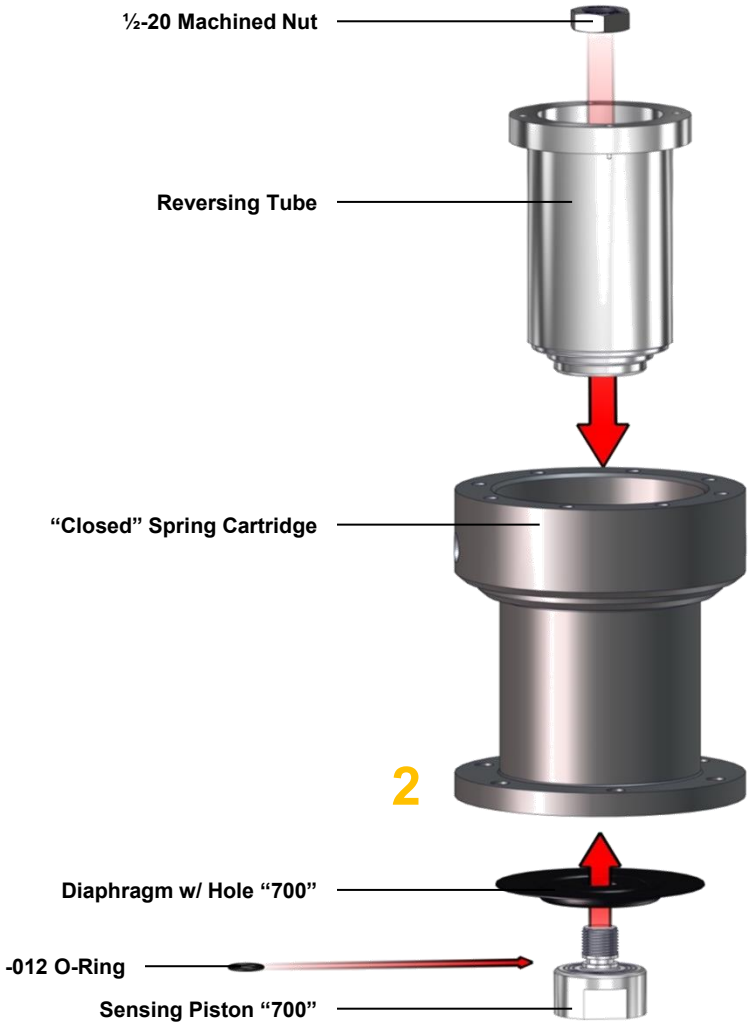

VRG
CONTROLS

VPC-700-SA-BV
Pilot Instructions

Assemble Closed Spring Cartridge Assembly



Instructions:

1. Lubricate and Install -012 O-Ring onto -700 Sensing Piston
2. Install -700 Diaphragm with convolute facing DOWN onto -700 Sensing Piston
3. Engage -700 Sensing Piston & Diaphragm into bottom of Closed Spring Cartridge
4. Insert Reversing Tube into Top of Closed Spring Cartridge
5. Using a 3/4 in Deep Well Socket, Install 1/2 - 20 Machined Nut to engage entire assembly and tighten to 110 in-lbs.

Install Closed Spring Cartridge Assembly onto Pilot Blank Assembly

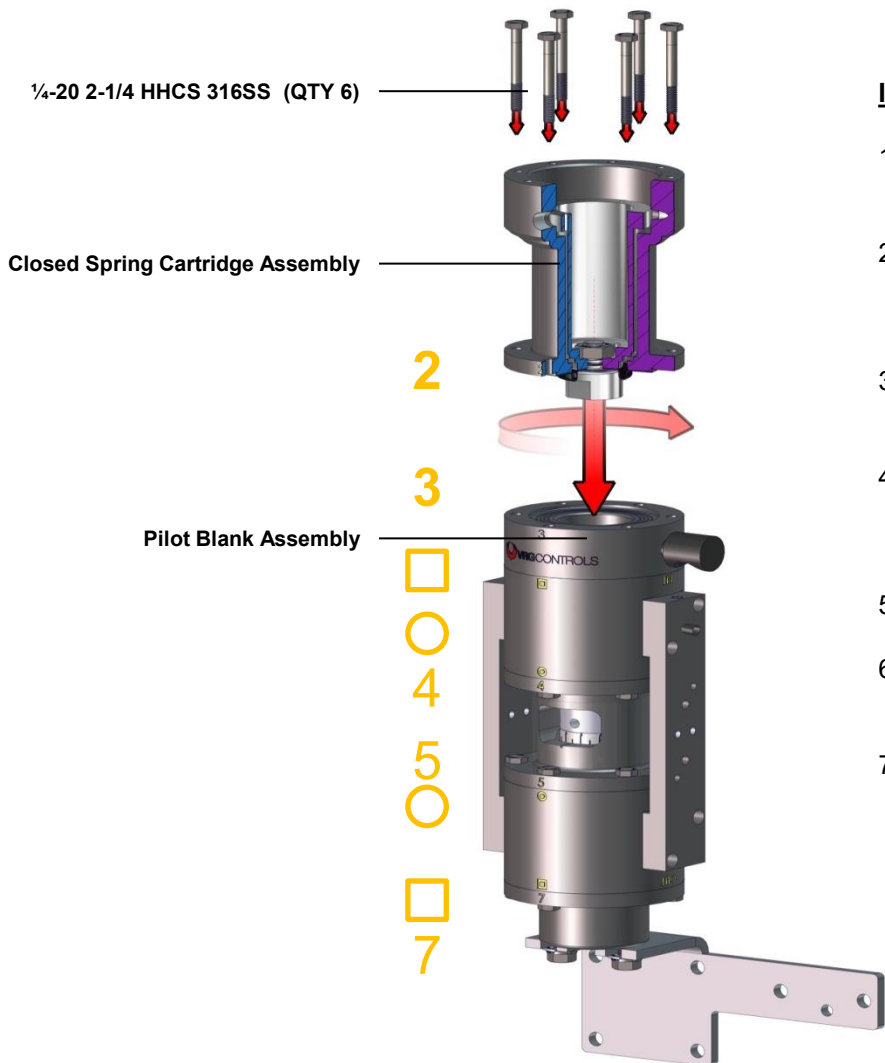

Instructions:

1. Install 1/4 NPT Vent Breather into NPT port on vent port on -700 Sensing Spacer
2. Align -700 Sensing Spacer with logo facing front of assembly (in-line with Adjusting Drum Window)
3. Push -700 Sensing Spacer onto Pilot Blank Assembly
4. Thread entire Closed Spring Cartridge Assembly onto BV Piston on top of Pilot Blank Assembly until it is fully engaged.
5. DO NOT TIGHTEN BEYOND FINGER TIGHT.
6. Rotate until #2 aligns with #3 on front of assembly.
7. Install 1/4-20 2-1/4 HHCS 316SS and tighten firmly in star pattern (QTY 6)

Pilot Blank Assembly with Closed Spring Cartridge Assembly Installed



Pilot Blank Assembly with Closed Spring Cartridge Assembly Installed

- 2
- 3
- △
-
- 4
- 5
-
-
- 7

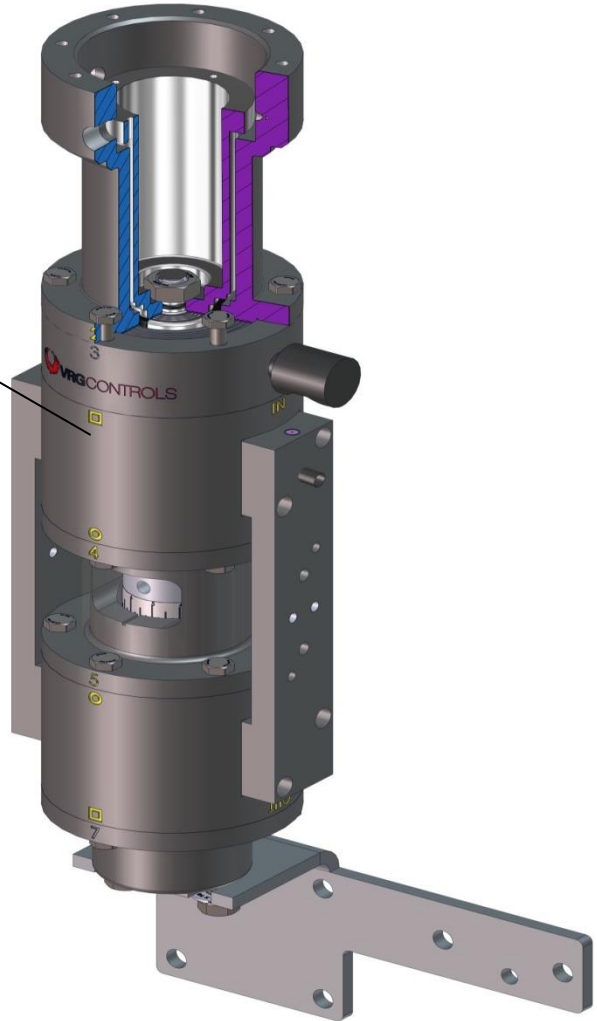

Assemble Setpoint Screw Assembly

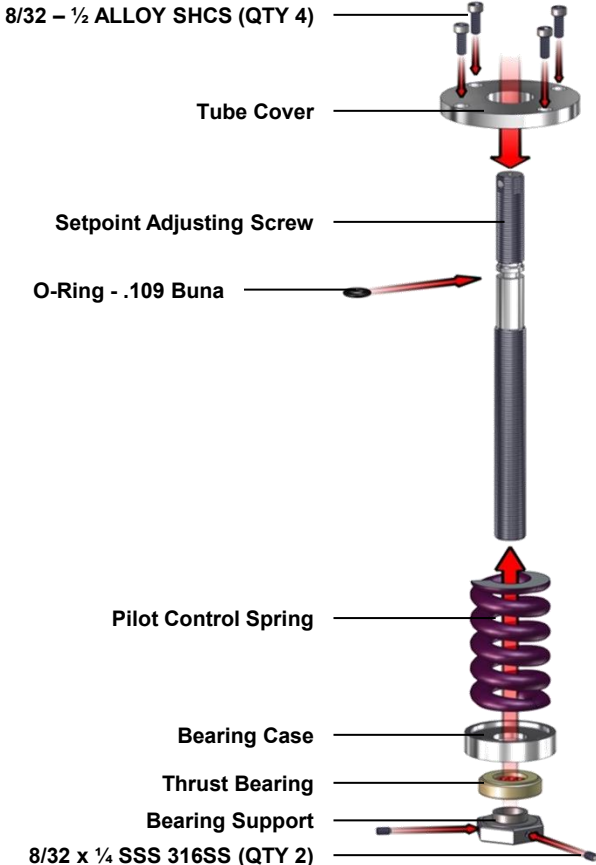

Instructions:

1. Mount bearing support onto Setpoint Adjusting Screw with 8/32 x 1/4 SSS (Self-Locking).
2. Press Thrust Bearing into Bearing Support with stamped letters side first. Thrust Bearing should fit snugly inside Bearing Support and bearing surface should face outward and rotate freely.
3. Install Bearing Support/Bearing Assembly onto Setpoint Adjusting Screw
4. Thoroughly lubricate and Install Pilot Control Spring onto Adjusting Screw
5. Lubricate -109 O-Ring and install in groove at top end of Adjusting Screw
6. Place 8/32 - 1/2 ALLOY SHCS in through holes of Tube Cover and slip over top of Setpoint Adjusting Screw

Install Setpoint Adjusting Screw Assembly

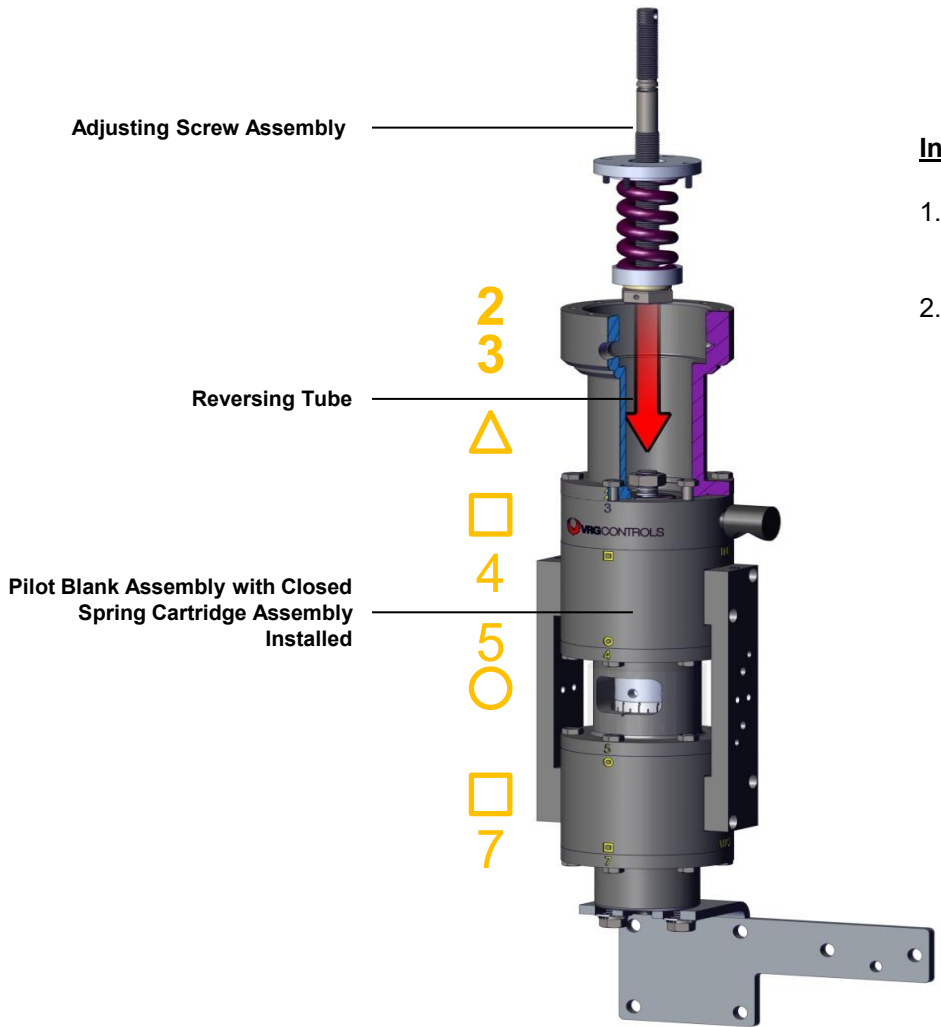

Instructions:

1. Slip entire Setpoint Adjusting Screw Assembly into Reversing Tube
2. Tighten 8/32 – 1/2 ALLOY SHCS in star pattern. Hold opposing side of Tube Cover down when tightening first screw to ensure proper alignment when tightening



Install Spring Cartridge Cap Assembly

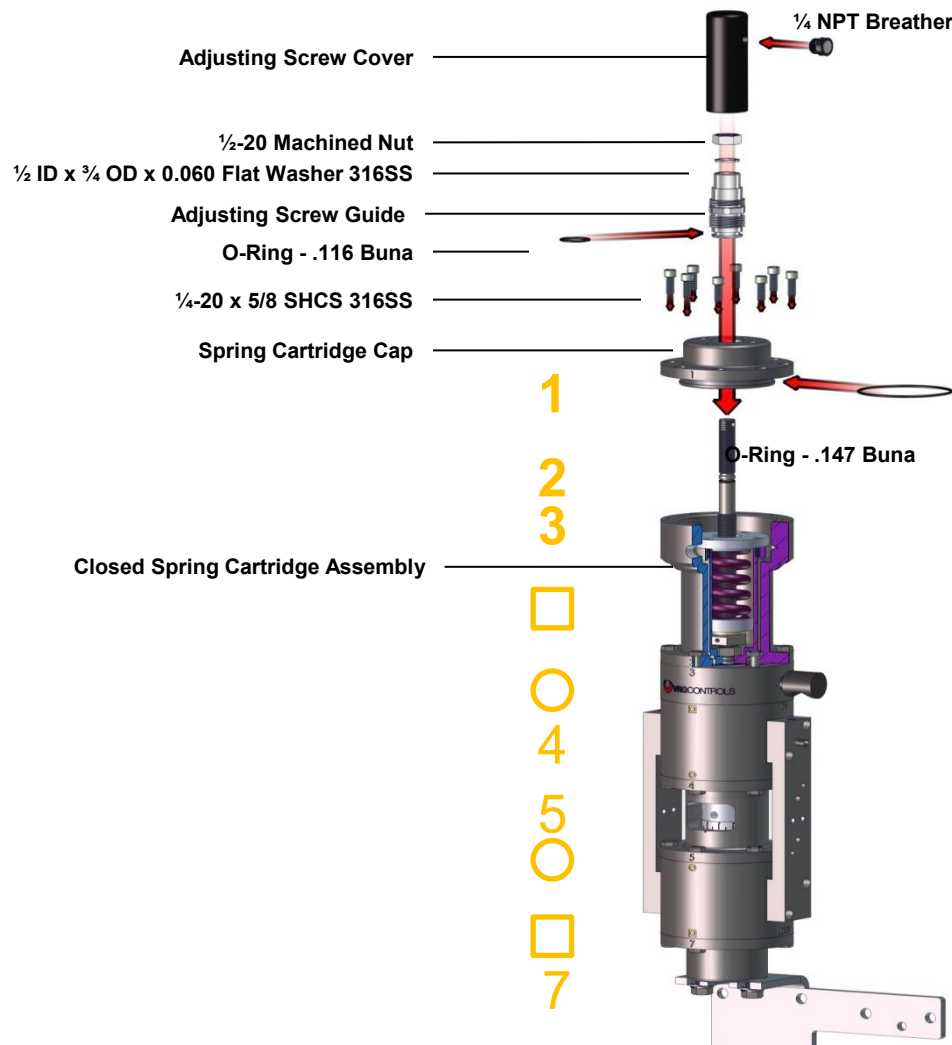

Instructions:

1. Lubricate -116 O-Ring and Install on Adjusting Screw Guide
2. Lubricate -147 O-Ring and Install on Spring Cartridge Cap
3. Thread Adjusting Screw Guide into Spring Cartridge Cap and Tighten
4. Drop Spring Cartridge Cap/Adjusting Screw Guide Assembly onto Setpoint Adjusting Screw and push over O-Ring.
5. Continue to install Spring Cartridge Cap Assembly by threading onto Setpoint Adjusting Screw. NOTE REVERSE THREADS.
6. Insert all 1/4-20 x 5/8 SHCS 316SS into Spring Cartridge Cap and tighten in star pattern until fully engaged. Tighten fully in star pattern.
7. Install Flat Washer and 1/2 - 20 Machined Nut.
8. Install 1/4 NPT Breather Vent into Adjusting Screw Cover and thread assembly onto Setpoint Adjusting Screw.



Pilot Blank Assembly with Spring Cartridge Cap Assembly Installed



Install Adjustable Orifice into SA Loading Manifold



Instructions:

1. Install 3/16 x 1/2 Roll Pin into SA Loading Manifold
2. Apply thin film of lubricant to .010 O-Rings to facilitate assembly.
3. Install .010 O-Rings in cavities on SA Loading Manifold
4. Install .010 O-Rings on Adjustable Orifice and Orifice Nuts
5. Insert Adjustable Orifices into DA Orifice Manifold
6. Install Orifice Nuts and Tighten. Be careful to ensure proper installation of O-Rings.

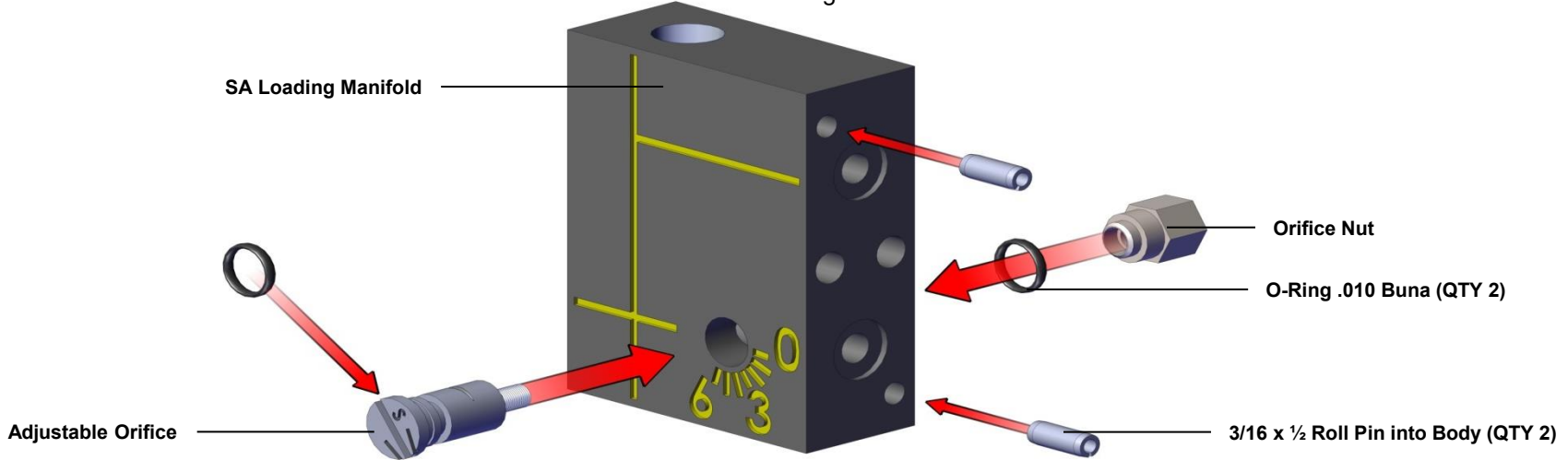

Install SA Loading and Unloading Manifold Assemblies



Instructions:

- 1. Apply thin film of lubricant to .010 O-Rings to facilitate assembly.
- 2. Adhere .010 O-Rings to cavities on Loading and Unloading Manifolds
- 3. Install SA Loading and Unloading Assemblies on Connecting Manifolds using 1/4-20 2 3/4 SHCS 316SS.

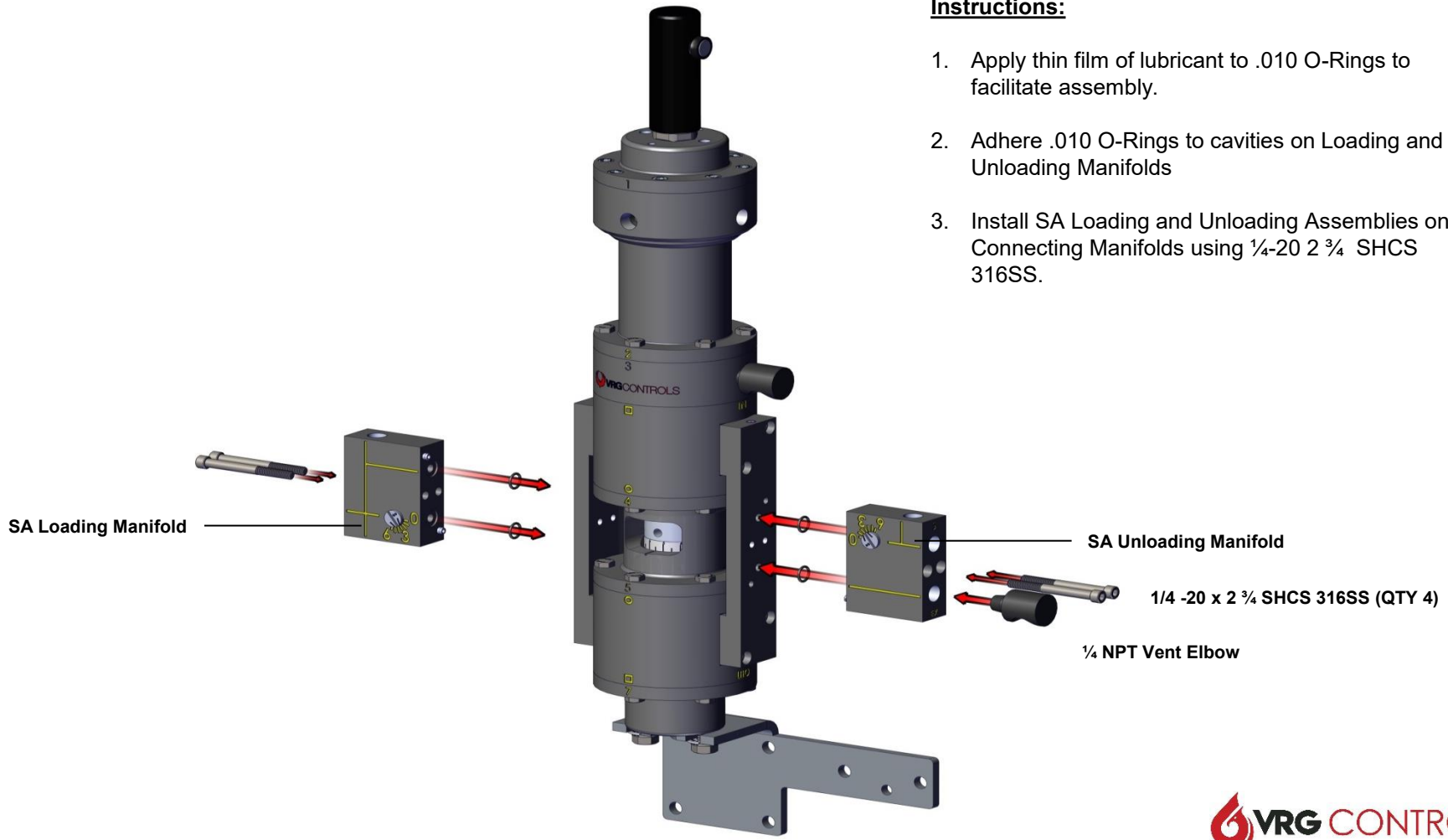





VPC-700-SA-BV Completed Assembly with Fittings & Gages Installed

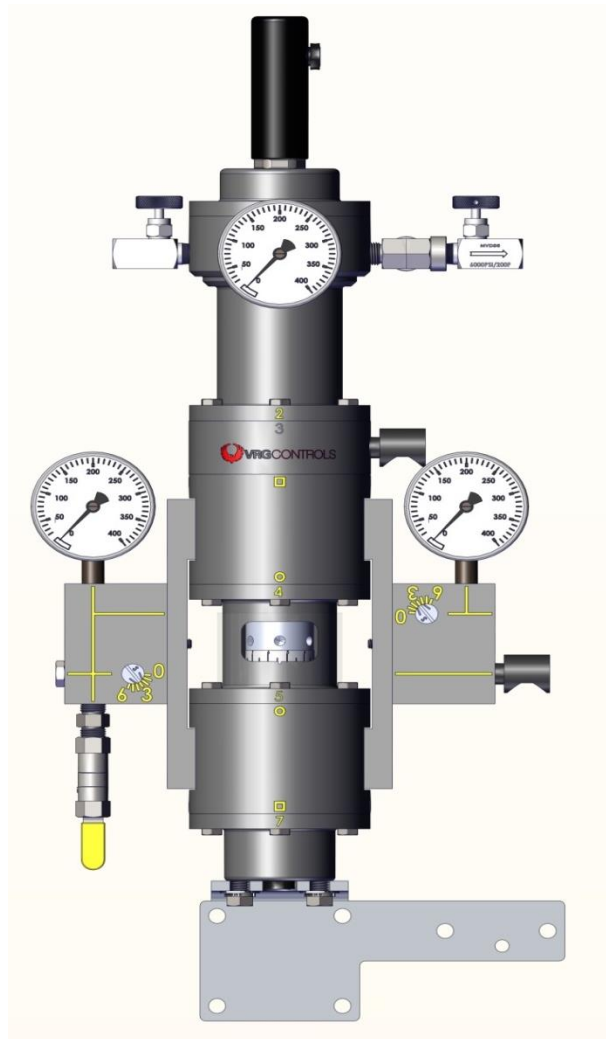

VPC-700-SA-BV Completed Assembly with Fittings & Gages Installed

